

# **Integrity Testing of Fabrics for Cleanroom Garments**

## **A New Method for Analyzing and Controlling the Filtration Efficiency of Cleanroom Clothing**

Matts Ramstorp

BioTekPro AB, Malmö and Division of Aerosol Technology, Department of Design Sciences, Lund University, Sweden

### **Summary**

Specialized textile fabrics have been used in cleanroom garments for many years. The need for this type of fabric has increased mainly due to the increasing need to protect critical operations in cleanrooms as well as to create a good enough comfort for operators and other personnel.

Despite the continuous development of textile fabrics as well as cleanroom garments several and more so, highly critical questions still needs to be answered:

- On what ground do manufacturer of textile fabrics and (or) cleanroom garments state that their products are suitable for use in a certain cleanroom class?
- How can these fabrics and garments be controlled in order to fulfil the demands stated by end-users as well as regulatory authorities?
- How can the life-time of these products be examined and controlled, especially when the garments have to be sterilized prior to use.

This presentation covers the general background in regards to the filtration efficiency of cleanroom fabrics and garments. Furthermore, it introduces a new and improved method for testing fabrics as well as cleanroom garments; a method that is more practical and sensitive as compared to traditional methods used today and based on a more concise technical approach.

### **Introduction**

Cleanrooms and other controlled environments are increasingly utilized in laboratories and industries working with manufacturing and handling of high technology products (1, 2). Controlled environments are also being used in operating theatres when performing high risk operations. The major reason for using this technology is to create a controlled environment, in regards to the number concentration of particles, including microorganisms, in the surrounding air.

The number concentration of particles in cleanrooms is mainly controlled by introducing filtered ventilation air. The ventilation is intended to remove contaminants, mostly particles, which are generated during various activities performed. The generation of contaminants is, from a general point of view, dependent on the activities undertaken. The presence of personnel is one of the most critical sources of particulate contaminants (3, 4), especially due to the vast number of particles that are released when old skin is renewed. The released particles from humans consist of dead particles as well as microorganisms.

The impact of humans on air cleanliness in controlled environments is, however, controlled. This is done by introducing filtered ventilation air, but even more so by dressing personnel in specialized clothings, so called cleanroom garments. This type of garment is aimed to act as a barrier between the operator and the surrounding air, and thus act as a filter. The

development of cleanroom fabrics, in general, has followed the increasing need for cleaner environments, and today 100 % polymeric materials are often used.

The information available for choosing and evaluation of cleanroom garments can be found in a document published by the Institute of Environmental Sciences and Technologies, the IEST, of the United States. In the document IEST-RP-CC-003 (5), several different tests are described.

### **Methods for testing textile materials**

Traditional methods in order to study and control textile materials used for cleanroom clothing involve several different tests. The confusion in industry is great, both in regards to the parameters that are measured and how the results obtained are to be interpreted. The most commonly asked question amongst end-users is: How many times can the cleanroom garment be washed and subsequently autoclaved, and still keep its integrity? Two distinct types of tests are available in this respect:

- Non-destructive tests, often called integrity tests, where some type of physical parameter, capable of being correlated to a challenge test, is studied. A non-destructive test should not involve any challenge of contaminant to the fabric and should ideally not affect the material in any way.
- Destructive tests, so called challenge tests, where the textile fabric is challenged with some type of particulate contaminant, in order to study its ability to filter out these particles.

### ***Traditional integrity testing of fabrics***

The “bubble point method” has been used for many years to study the filtration efficiency of membrane filters as well as textile materials. The bubble point method used for fabrics is described in a British Standard that has been incorporated in the Recommended Practice, IEST-RP-CC-003 (5).

The bubble point test for fabrics involves the following steps:

- Wetting of the textile material with a suitable wetting liquid, often consisting of water and isopropyl alcohol.
- Installing of the pre-wetted textile material in a semi-opened filter holder, with a diameter of 47 mm.
- Applying a gas, normally pressurized air, to the lower inlet of the filter holder.
- Increasing the gas pressure in a step-wise manner across the wetted textile material. When increasing the gas pressure, the opened side of the wetted textile material is observed in order to identify bubbles, i.e. gas passing the fabric.
- When the “third” bubble is visible on the wetted fabric, the gas pressure is recorded and used in the calculation of the “Equivalent Pore Size” of the textile material.

### ***How to determine the pore size of a porous material***

The bubble point method has since long time been used to study the integrity of membrane filters used for microbial retention. The test used on membrane filters is based on measuring several parameters after which Equation (1) is used to calculate the pore diameter of the filter medium:

$$D = \frac{4 \gamma \cos \Phi}{P} \quad \text{Equation (1)}$$

Where:  $D$  is the pore diameter of the filter medium (m)  
 $\gamma$  is the surface tension of the wetting liquid (N/m)  
 $\Phi$  is the wetting angle between the wetting liquid and the filtration media  
 $P$  is the bubble point pressure (N/m<sup>2</sup>)

In the Recommended Practice (5), the bubble point pressure is used to calculate the equivalent pore diameter using Equation (2):

$$D = \frac{4 T 10^6}{Z P g} \quad \text{Equation (2)}$$

Where:  $D$  is the equivalent pore diameter  
 $T$  is the surface tension of the wetting liquid (mN/m)  
 $Z$  is the density of the wetting liquid (g/(mm)<sup>3</sup>)  
 $P$  is the bubble point pressure (mm water head)  
 $g$  is the gravitation (m/s<sup>2</sup>)

The bubble point test, either calculated with Equation 1 or Equation 2 results in what is called the pore size, which in turn is stated to be a measure of the filtration efficiency of the porous material.

The bubble point method has several drawbacks:

- It is a subjective method, since it is dependent on the operator to determine when the “third” and often very tiny bubble is visible.
- The test result is, furthermore, not a good measure of the filtration efficiency of a fabric. The efficiency of a filter material, a textile fabric or a process filter, is not only dependent on the pore size of the filter medium. The filtration efficiency is in general much more dependent on the thickness together with the porosity of the material, which today is a quite common knowledge in regards to micro porous filters.

## Materials

<i>Filterholder:</i>	293 mm, Millipore Intel YY3029316
<i>Pressure indicator:</i>	DPI 705, GE Druck Ltd, Leichester, UK
<i>Pressure regulators:</i>	Beccofrem CCRO, Serto 47021, Hoke 1315G4B
<i>Flow meter:</i>	Primary Flow Calibrator, Gillian Instruments
<i>Chemicals:</i>	The water used for wetting was deionised. All other chemicals were of analytical grade.
<i>Aerosol generator:</i>	PALAS BEG-1000, Palas GmbH, Germany
<i>Aerosol:</i>	Glass particles
<i>Particle counter:</i>	Aerodynamic Particle Sizer Model 3321 (APS) TSI Inc. USA

*Fabrics:*

The fabrics tested were cut from new and used cleanroom garments, respectively. The used fabrics were washed in a cleanroom laundry facility prior to testing.

## Methods

### ***The bubble point test***

In order to evaluate the bubble point test, this was performed according to the description published in the document from IEST (5).

### ***The developed integrity test***

The integrity test developed is based on the same basic principle as the bubble point test. The fabric to be tested is wetted with a suitable liquid and placed in the filter holder. Pressurized air is applied to one side of the fabric and increased in minute steps. The system is allowed to stabilize between each pressure increase. The gas flow, in the beginning, as a result of diffusion, is measured with a gas flow measuring device. This is continued until the bubble point pressure is reached. The experimental set-up schematically illustrated in Figure 3.

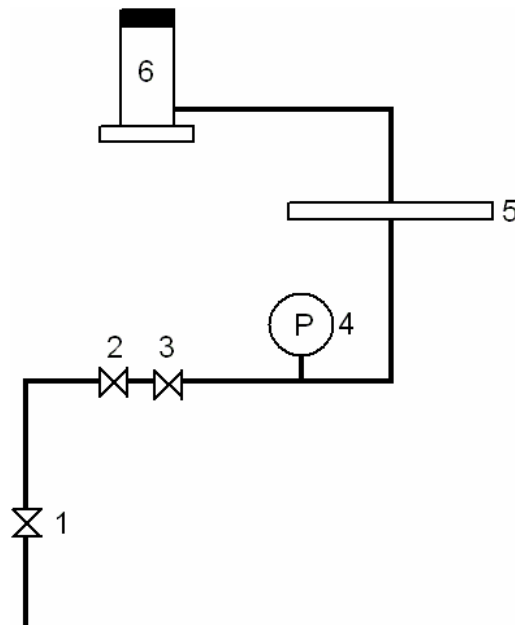

Figure 1. Schematic illustration of the experimental set-up for performing the integrity test on fabrics. Pressurized air is reduced with valves, 1 – 2. The final reduction of pressure is performed with valve, 3, (the fine adjustment valve). Air pressure to the downstream side of the fabric is monitored with a pressure gauge, 4. The air is introduced into the 293 mm filter holder, 5, in which the wetted fabric to be tested is placed. Air penetrating the fabric, either by diffusion or by massive gas flow, is passed forward to the flow metering device, 6.

### ***The destructive test***

Pressurized air (2 bar overpressure) transports glass particles produced in an aerosol generator into an equilibrium environment with a volume of 1 m<sup>3</sup>. The aerosol was subsequently drawn through the dry fabric to be tested (4 L/min) placed in the filter holder. The particles passing through the fabric is then measured with a particle counter. The experimental set-up of the destructive test is schematically illustrated in Figure 5.

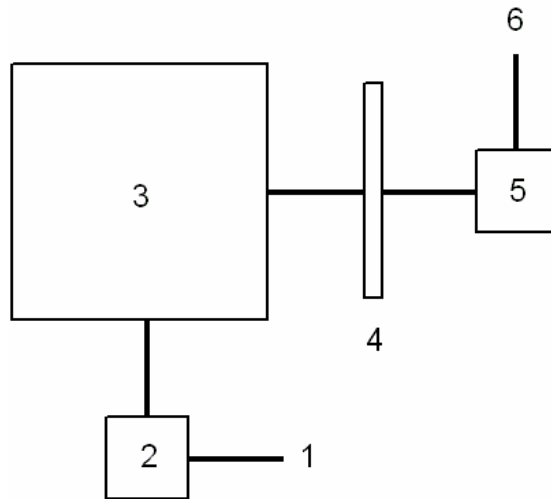

Figure 2. Schematic illustration of the experimental set-up for performing the challenge test on fabrics. Pressurized air **1** transports glass particles produced in an aerosol generator **2** into an equilibrium environment **3**. The aerosol was subsequently drawn through the dry fabric placed in the filter holder **4** by means of a pump **6**. The particle content of the air passing through the fabric is measured with a particle counter **5**.

## Results and Discussion

### *The bubble point test*

The bubble point method was used to study various textile fabrics. These tests were performed on single layer as well as double layer fabrics, respectively. These results are shown in Table 1. All fabrics tested were new and have not been washed prior to test.

Textile	Intended use	Stated pore size (µm)	Calculated pore size (µm)
A single	Cleanroom	20	30.9
A double	Cleanroom	20	26.1
B single	Controlled Environment	27	54.8
B double	Controlled Environment	27	49.1
C single	Controlled Environment	Not specified	49.8
C double	Controlled Environment	Not specified	50.6
D single	Inner garment	Not specified	78.2
D double	Inner garment	Not specified	74.5
E single	Cleanroom	Not specified	41.6
E double	Cleanroom	Not specified	39,4
F single	Cleanroom	16	48.8
F double	Cleanroom	16	43.6
G single	Cleanroom	Not specified	8
G double	Cleanroom	Not specified	8

Table 1. Different fabrics where tested with the bubble point method as stated in (5). The table illustrates the manufacturers intended use of the fabric, the stated pore size of the fabric together with the equivalent pore diameter from the measurements performed in this study. The stated pore size are given by the manufacturer.

The results obtained shows that the equivalent pore diameter is approximately the same when comparing one sheet of fabric with two sheets on top of each other.

Another way to measure the filtration efficiency of a fabric is to challenge it with artificial contaminants, such as solid particles. Figure 3 shows the filtration efficiency of a single layer of fabric (G in Table 1) in relation to the particle size.

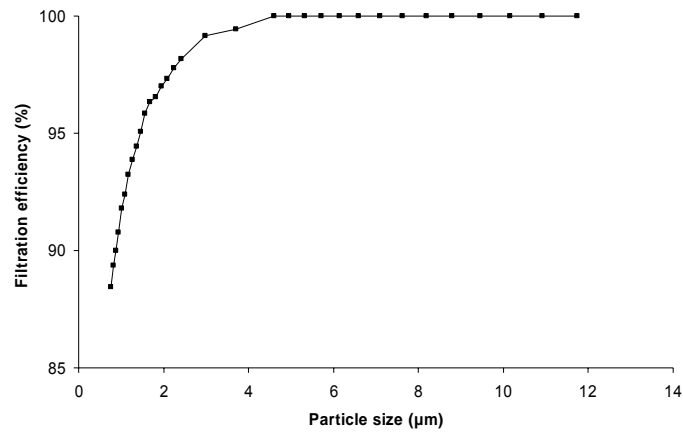

Figure 3. The filtration efficiency of a single layer of Fabric (G in Table 1), when challenged with glass particles of various sizes.

Figure 4 shows the filtration efficiency measured with particles of a double layer of fabric (G in Table 1) in relation the particle size.

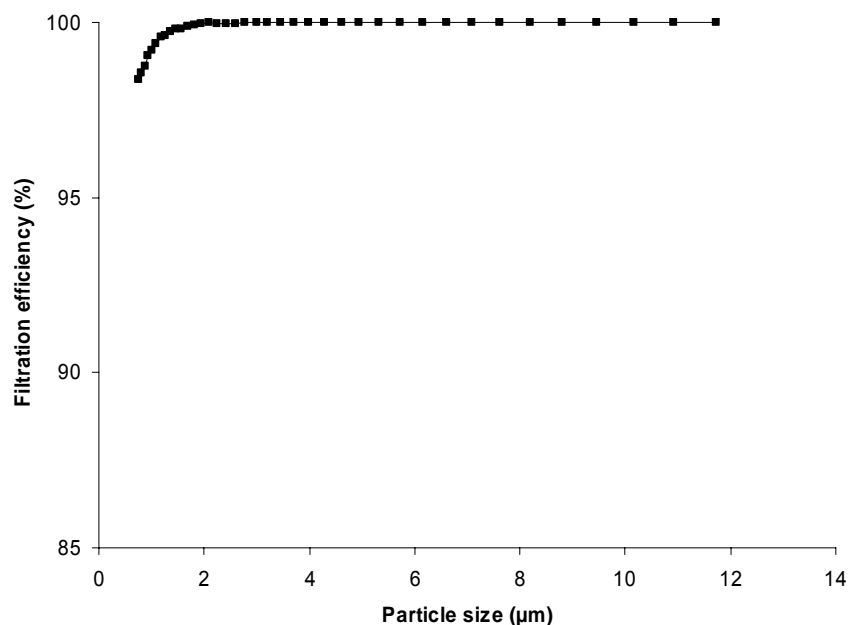

Figure 4. The filtration efficiency of a double layer of Fabric G in Table 1, when challenged with glass particles of various sizes.

When comparing the filtration efficiency of a single and a double layer of Fabric G, respectively, it is quite obvious that the double layer fabric is a much better acting filter when compared to a single layer fabric. This is not quite obvious when looking at the results obtained from the bubble point test, where the measured pore size for a single layer and a

double layer of fabric is nearly identical. The term pore size is thus not a good measure of the filtration efficiency!

### ***The new integrity test on fabrics***

If a wetted porous material is placed in a test system to which a pressurized gas is applied on one of the sides of the fabric, the pressurized gas is enclosed and can only exit through the fabric, either by diffusion or by pure gas flow. At low pressure the gas will pass the fabric by diffusion and pure gas flow is only obtained as a certain elevated gas pressure is reached. The applied gas pressure at which the first and largest pore is expelled of its liquid content is called the bubble point pressure. Figure 1 and Figure 2 illustrates the gas flow through two different wetted fabrics in relation to the applied gas pressure.

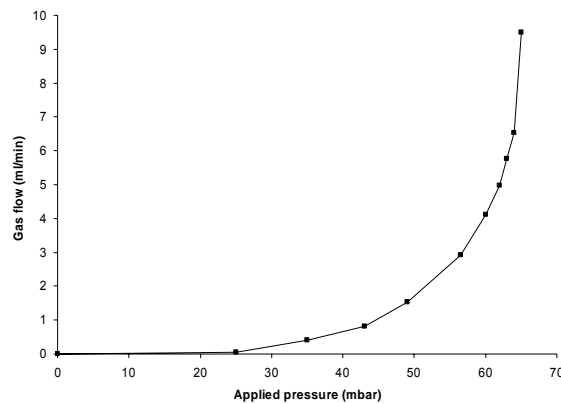

Figure 5. A cleanroom fabric subjected to the new integrity test. The test pressure is increased in a minute stepwise manner and the gas flow passing through the fabric is measured on the downstream side.

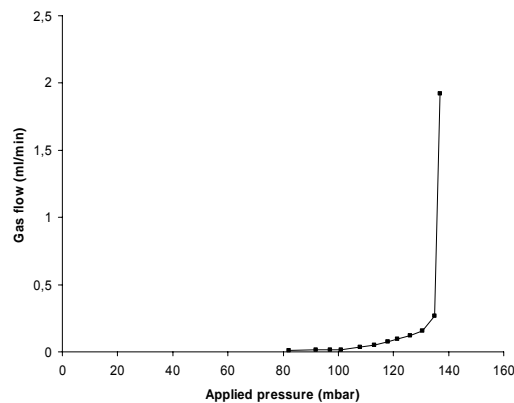

Figure 6. Another cleanroom fabric subjected to the new integrity test. This fabric is much more homogeneous than the one described in Figure 1.

The bubble point pressure is the point on the graph where the flow increases dramatically. It is quite difficult to determine the bubble point pressure when looking at the fabric described in Figure 1, as compared to the very dramatic change in gas flow that is observed from the fabric shown in Figure 2.

### ***How to use this new integrity test on fabrics?***

Gas flow through a porous material can be calculated using Equation 3.

$$N = \frac{D \delta P p}{L} \quad \text{Equation 3.}$$

Where:  $N$  is the diffusive flow of gas (m<sup>3</sup>/h)  
 $D$  is the diffusivity of gas through the wetting liquid (m/h)  
 $\delta P$  is the differential pressure across the porous material  
 $p$  is the porosity of the porous material  
 $L$  is the thickness of the porous material (m)

As is seen from Equation 3, the gas flow is dependent on porosity as well as thickness of the porous material. This is a more accurate approach in order to determine the filtration efficiency of porous materials.

In order to use the integrity test developed for analytical purposes, all fabrics have to be screened in order to obtain its respective profile, as is shown in Figure 1 and Figure 2, respectively. The bubble point pressure is established for each fabric and a test pressure is chosen at approximately 75 % of the bubble point pressure. The gas flow through the fabric at this test pressure is established and used in order to study the aging of cleanroom clothing.

When cleanroom clothing becomes worn the gas flow due to diffusion will change in a manner similar to that shown schematically in Figure 4, i.e. the diffusion will increase as the fabric is washed and autoclaved. The maximum allowed gas flow through the fabric has to be determined, in order to be able to state when the garment in question has to be taken out of use.

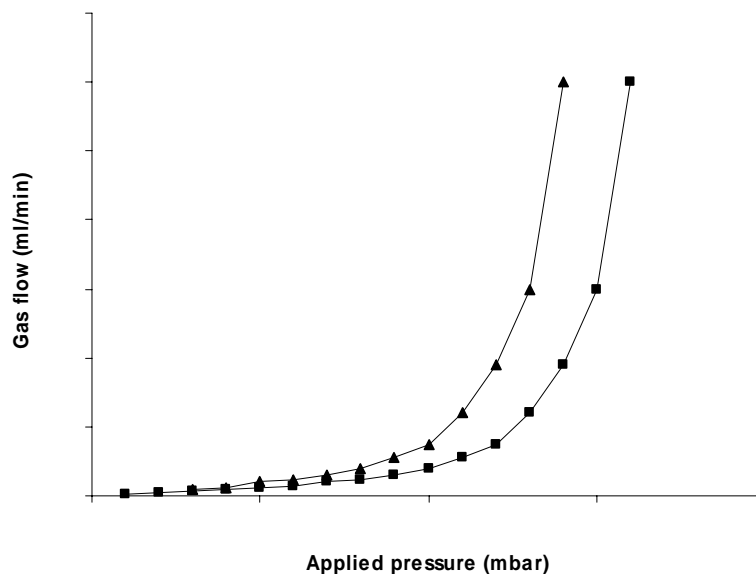

Figure 4. Schematic illustration of how the diffusional gas flow across a fabric will change as it becomes aged due to washing and autoclaving. (■) illustrates a new fabric, whereas (▲) illustrates a fabric that is aged and worn out.

## **Conclusion**

During the experiments performed it was quite obvious that the bubble point test has serious drawback when used to study the filtration efficiency and thereby the aging of cleanroom fabrics. The most critical drawbacks are that the equivalent pore diameter is not a good measure of the filtration efficiency of the fabric together with the fact that the bubble point test is operator dependent.

The new integrity test method introduced in this presentation is a better method in order to study the homogeneity as well as the filtration efficiency of fabrics and is also a method that is quite easy to use, after a profile of the fabric has been obtained. The new method has been used in industry at a cleanroom laundry company as well as a university in Sweden for two years now. Further results will be published.

## **Acknowledgement**

This work has been gratefully supported financially by the Swedish Council for Textile Research.

## **References**

1. M. Ramstorp, Introduction to Contamination Control and Cleanroom Technology (2000), Wiley-VCH Verlag GmbH, Weinheim, Tyskland
2. W. Whyte, Cleanroom Technology – Fundamentals of Design, Testing and Operation (2001) John Wiley & Sons Ltd, Chichester, England
3. P.R. Austin, S.W. Timmerman, Design and Operation of Clean Rooms (1965), 235 – 251, Bussiness News Publishing Co, Detroit, USA
4. M. Ramstorp, M. Gustafsson, A. Gudmundsson (2005), 1572 – 1576, Particle Generation from Humans – A method for Experimental Studies in Cleanroom Technology, Proceedings of the 10<sup>th</sup> International Conference on Indoor Air Quality and Climate 2005, Beijing, Kina
5. Garment System Consideration for Cleanrooms and Other Controlled Environments (2003), IEST-RP-CC-003.3, Institute of Environmental Sciences and Technologies, Rolling Medows, USA

Accepted for presentation and publication:

The 18<sup>th</sup> International Symposium on Contamination Control (ICCCS ) & China International Exhibition on Contamination Control 2006 September 6<sup>th</sup> ~ 7<sup>th</sup> 2006, Beijing, China